



**BLUELINE**<sup>®</sup>  
Vacuum Technologies, Inc.

# FICHA TÉCNICA

NEPTUNE<sup>®</sup> 20

## *Bomba de Vacío de Doble Etapa*

Conexión de Entrada	KF25
Conexión de Salida	KF25
Velocidad de Bombeo a 60 Hz	19.2 m <sup>3</sup> / hr
Presión parcial final	4x10 <sup>-4</sup> mbar
Tolerancia al Vapor de Agua a 60 Hz	28 mbar
Capacidad de Vapor de Agua a 60 Hz	91 g/hr
Fluido de Operación	UG20
Capacidad de Aceite en Litros	1.5
Nivel de Ruído	58 dB
Potencia del Motor	0.55 kw, 0.73 hp, 110V, 60 Hz
Velocidad de rotación a 60 Hz	1720
Temperatura ambiente	5-40°C
Peso	30 kg

- Robusta y confiable



Neptune 20

Incluye  
Gas Ballast

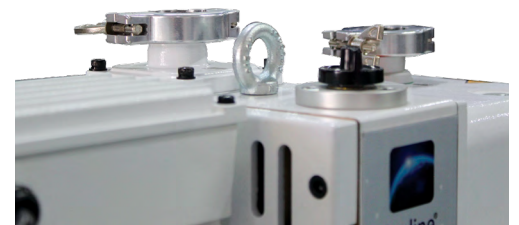

- Calidad suprema  
de manufactura



# CAPACIDAD DE BOMBEO Y

## DIMENSIONES

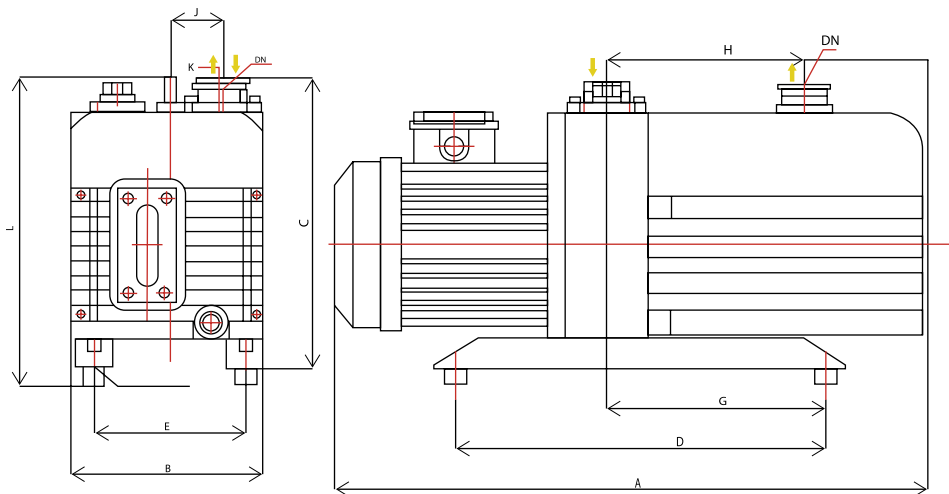
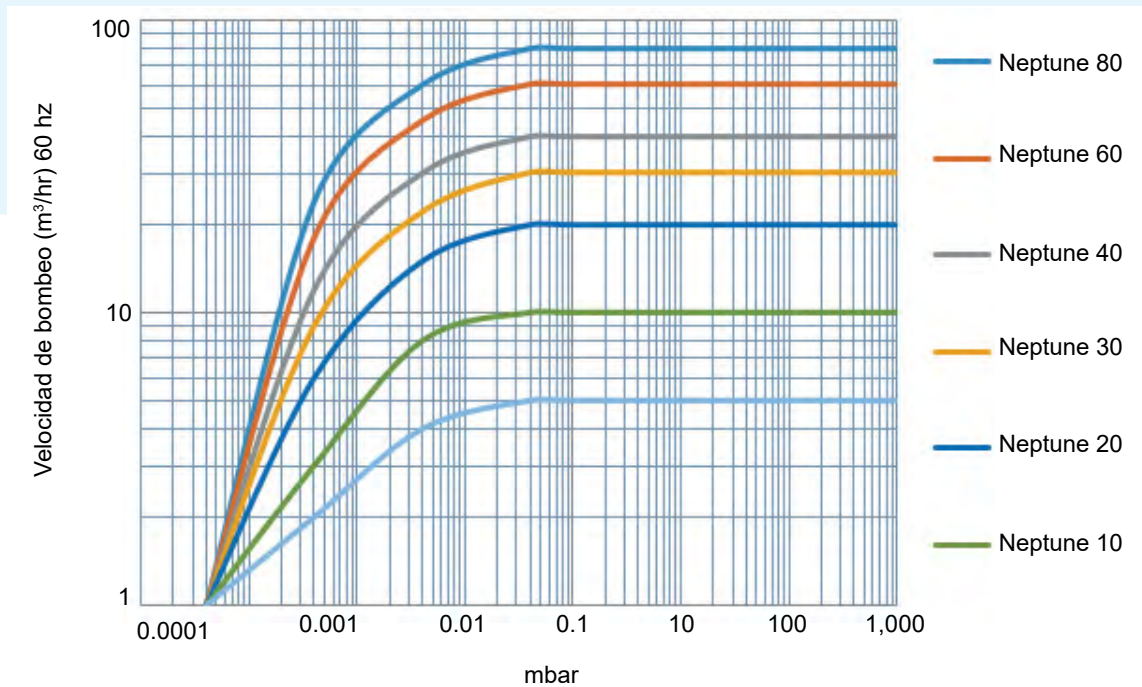

MODELO	A	B	C	D	E	F	G	H	I	J	K	L
Neptune 20	520	188	272	320	148	-	160	165	69	59	38	295

