



BLUELINE[®]
Vacuum Technologies, Inc.

FICHA TÉCNICA

TITANIUM B[®] 100

Bomba de Vacío de Una Etapa

Conexión de Entrada	G 1-1/4"
Conexión de Salida	G 1-1/4"
Velocidad de Bombeo a 60 Hz	120 m ³ / hr
Presión Final sin Gas Ballast	0.5 mbar
Presión Final Parcial con Gas Ballast	1 mbar
Tolerancia al Vapor de Agua a 60 Hz	30 mbar
Capacidad al Vapor de Agua a 60 Hz	600 grams./hr.
Fluido Operativo	UG40S Oil
Capacidad de aceite de operación en litros	2
Nivel de ruido	74 Db
Clasificación del motor	3 kw / 4hp / 220V / 3ph / 60 Hz
Velocidad de rotación a 60 Hz	1720
Temperatura Ambiente Admisible	12 a 40 Celsius
Peso	85
No. de filtros de salida	2
Enfriamiento	Aire

- Robusta y confiable



Titanium B 100

Incluye
Gas Ballast



- Calidad suprema
de manufactura

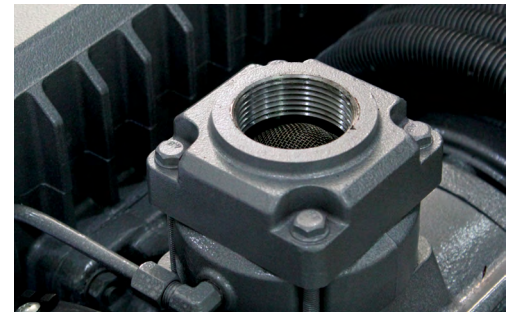

CAPACIDAD DE BOMBEO Y

DIMENSIONES

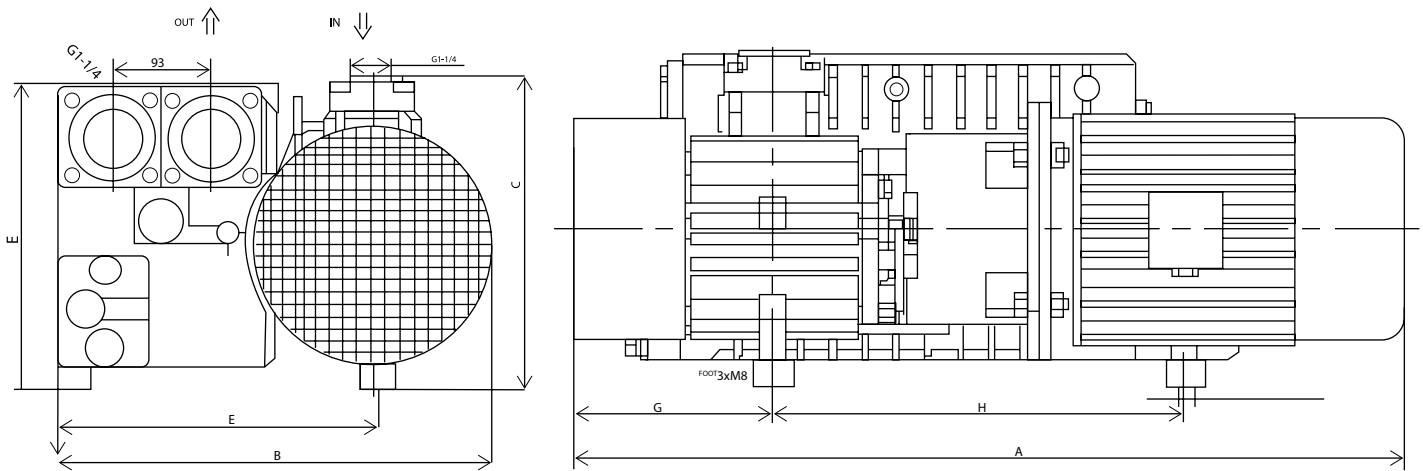
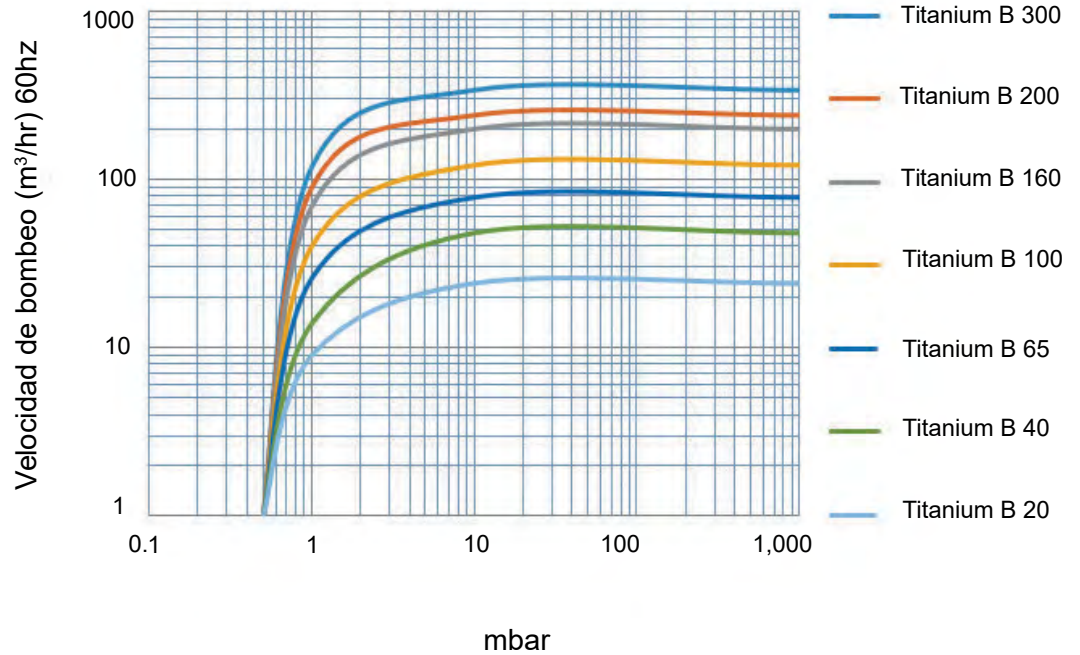

MODELO	A	B	C	D	E	F	G	H	
Titanium B 100	735	420	295	20	285	-	185	317	(milímetros)

